

OPERATING THEATRE VIDEO SYSTEMS



Dr. Mach
Lighting Systems

Preparation for the camera



Technical Data

Colour film camera for visual communication (PAL)

Operating theatre lights		MACH 380	MACH 405	MACH 500	Camera	MFB-Mo ⁽¹⁾	OFB-Um ⁽²⁾ OFB-St ⁽³⁾
		DF-model	F-model	DF-model		F-model	DF-model
Light intensity Lux		110.000 90.000	135.000 110.000	150.000 130.000	item no.	46000001 (MFB-Mo)	46000003 (OFB-Um) 46000004 (OFB-St)
Colour rendering index R _a (gen.) at 4300 Kelvin		96	96	96	Lens system	72x zoom f=4.1 to 73.8 mm F1.4-3.0 AutoFocus (integrated focus system)	AutoFocus (integrated focus system)
Colour rendering index R _g (red) at 4300 Kelvin		92	92	92	Video output 75	Y: VS1.0 Vp-p. Sync. negative C: Burst 0.300 Vp-p VBS: 1.0 Vp-p Composite	Y: VS1.0 Vp-p. Sync. negative C: Burst 0.300 Vp-p VBS: 1.0 Vp-p Composite
Size of focusable luminous field		10-35 cm 17-28 cm	10-35 cm 17-28 cm	10-35 cm 17-28 cm	Image points	752 (H) x 582 (V)	752 (H) x 582 (V)
Electronic brightness control on lamp fitting		Surcharge	Surcharge	Surcharge	Horizontal resolution	more than 460 lines	more than 460 lines
Radiation intensity in field at 100,000 Lux		389 W/m ²	389 W/m ²	389 W/m ²	Vertical resolution	more than 400 lines	more than 400 lines
Temperature increase near head		2°C	2°C	2°C	Humidity	20% - 85%	20% - 85%
Total power consumption		162VA	216VA	269VA	Dimensions (Ø, length)	80mm x 150 mm	80mm x 150 mm
Number of bulbs: Halogen 22.8/24 V 50 W		3	4	5	Weight	900g	900g
Working distance		60-150 cm 70-140 cm	60-150 cm 70-140 cm	60-150 cm 70-140 cm	Interference radiation in acc. with	FCC Class A	FCC Class A
Height adjustment		115 cm	115 cm	115 cm			

⁽¹⁾ Remote control with picture rotation
⁽²⁾ Without remote control convertible to 1)

⁽³⁾ Without remote control not convertible to 1)

(Subject to change without notice owing to technical modifications)

MACH 700 also available with integrated video camera



kooperatives Mitglied der Zentralvereinigung Medizin-Technik

4000/07/2000



Mach 380/500

Video camera integrated in the center of the 3 reflector lamp

Mach 380/500/KA

3 and 5 reflector OT lamp combination with separate camera



Mach 405/500

Video camera integrated in the center of the 4 reflector lamp



Remote camera control
· 72x zoom
· Focus control (automatic/manual)
· Iris control (automatic/manual)
· Colour control
· Still picture
· Superimposed date and time
· Optional: picture rotation



Mach 405/500/TA

Like MACH 405/500, but with additional supporting arm for monitor

Dr. Mach Lighting Systems

- Note:
- All OT lamps featuring:
 - unparalleled colour rendition $R_a = 96$ and $R_9 = 92$ at 4300 Kelvin
 - computer-optimized multi-reflector system
 - open ring form to enhance flow properties
 - luminous field concentration
 - optional with Duo-Focus or Autofocus technology (operated from the sterilizable handle)
 - optional with preparation for camera to be retrofitted later

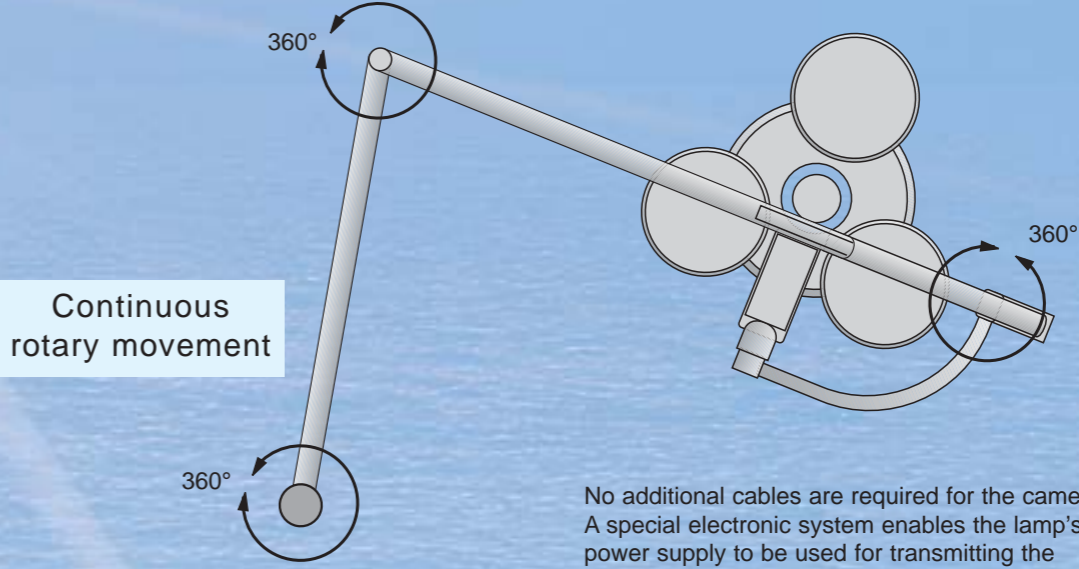

For further details kindly request our extensive brochure on single lamps.

No additional cables are required for the camera. A special electronic system enables the lamp's power supply to be used for transmitting the control and video signals.